

With these instructions, we will guide you step by step on how to install the 75 Flow sliding door system with a curved cover plate and a standard sliding door.

Before installing the sliding door, make sure that the wall and the floor around the doorway area are straight. At the same time make sure that there are support beams inside the wall, so that the wall brackets can be firmly attached to the wall. To find out where the support beams are located inside the wall, you can use wall scanner. If you cannot attach all the support screws to the support beams, use screw plugs to ensure that the screw remains in the wall.

## Tools required for installation:

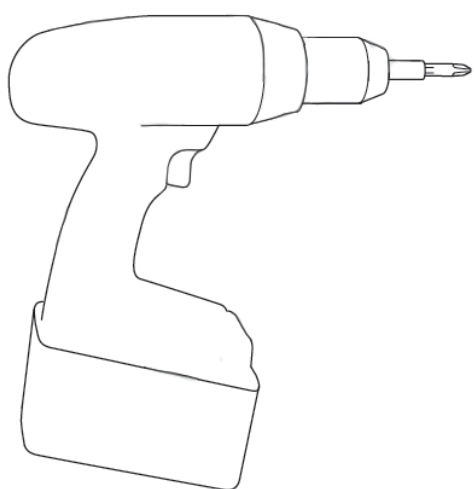

Screwdriver / drill

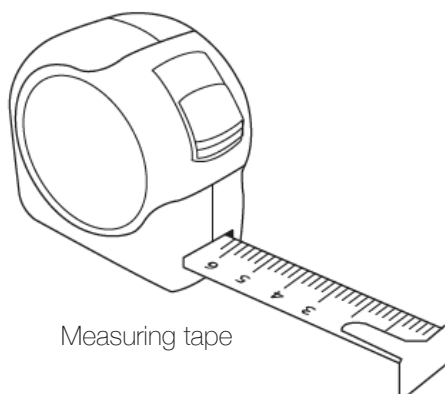

Measuring tape

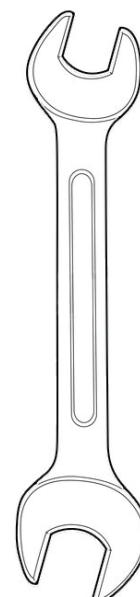

Thin wrench  
size 13

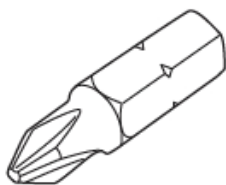

Crosshead -screw tip

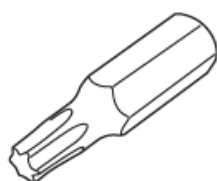

Torx 10 -screw tip

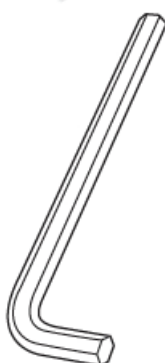

Hex key  
sizes 3 mm and 4 mm

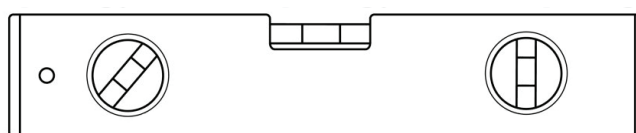

Level

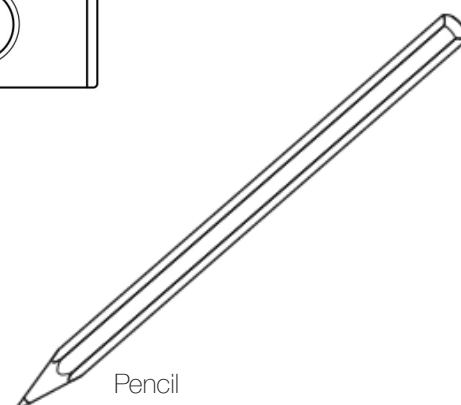

Pencil

## 1. Measure and mark the fixing height of the Track

The installation height is calculated as follows: **Door height + 85 mm**. This leaves a 12 mm gap between the floor and the door.

You can lower the door by approximately 7 mm with the hanger bolts after installation. *Note! Make sure that the hanger bolt is screwed all the way into the hanger body.*

After marking one point, draw a horizontal line on the wall using the spirit level along the entire track. This is how you mark the horizontal locations of the screws for each bracket.

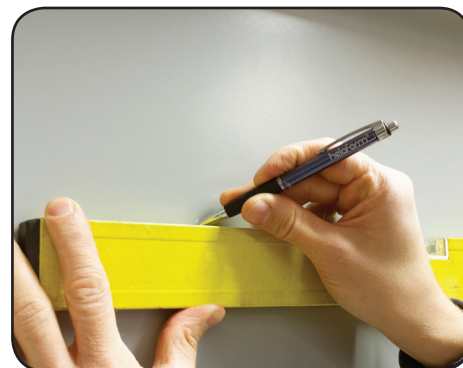
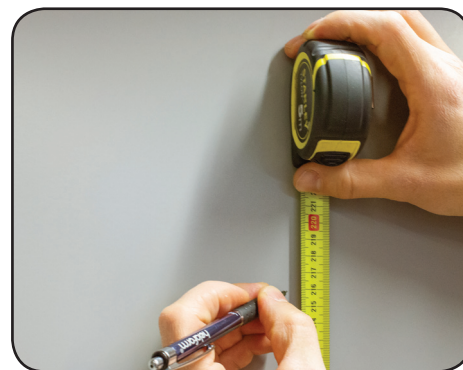

---

## 2. Slide the Wall brackets to the track

Slide the bracket lightly from the center so that it slides straight and effortlessly along the groove. Do not use force to prevent the bracket from “clipping”.

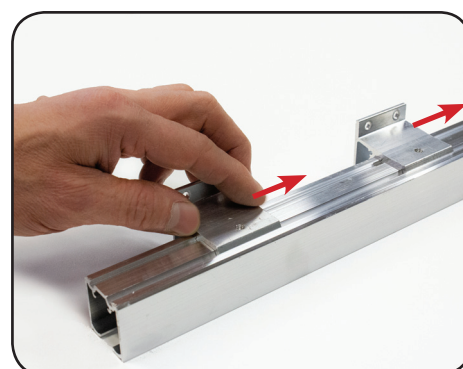

---

## 3. Mount the Brackets and the Track to the wall and finally tighten the clamping screws on the Brackets

If you are working alone, first tighten the center bracket to the wall with one screw so you can easily support the track when mounting the other brackets.



#### 4. Slide the parts in to the track. When inserting from the left end, parts come in the following order:

1. Stop KP-75 ("rubber part" behind)
2. Hanger MP-75 ("spearhead" above)
3. Hanger MP-75 ("spearhead" behind)
4. Stop KP-75 ("rubber part" above)

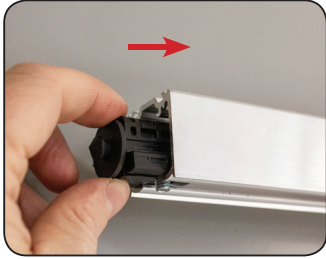

1

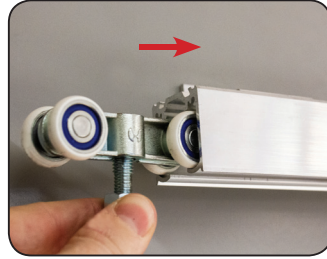

2

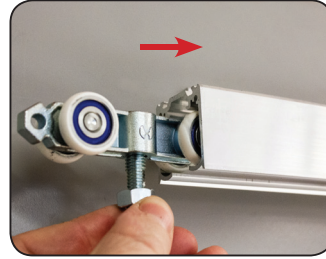

3

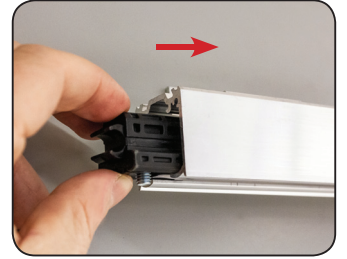

4

NB! If you have other accessories such as Soft close, see their installation instructions at [www.helaform.com](http://www.helaform.com)

#### 5. Attach the Plates to the door

Attach the plates to the door 1/5 of the door's width from the edge so that the slots of the bolts face the wall.

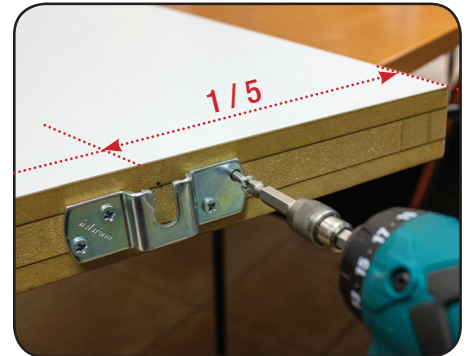
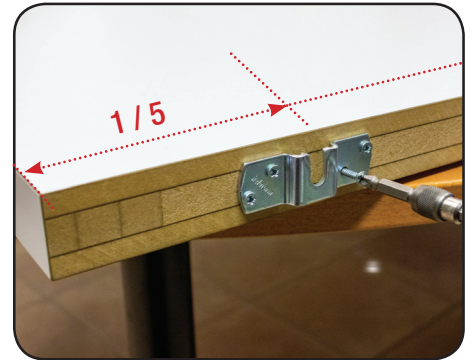

#### 6. Lift the door to its place

Adjust the height and position of the door by turning the hanger bolts. Tighten the nuts on to the plates.

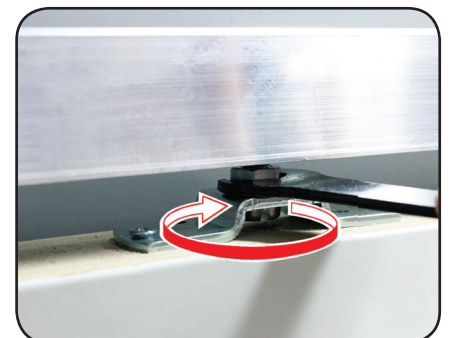

## 7. Install the Bottom guide

Position and mark the place of the bottom guide so that it is completely hidden when the door is at the "open" end. Slide the door out of the way and screw the bottom guide to the floor. The bottom guide should remain in the guiding groove throughout the entire movement of the door.



## 8. Move the Stop to the correct position

Move the stop to where you want the door to stop at the "open" and "closed" ends and tighten.

The best way to tighten with one hand is to push the stopper to the ceiling of the track while tightening it. Use a good tool to get a firm grip.



## 9. Install the Cover plate

Before installing the cover plate, make sure that the door and all parts are in the correct position, function and height.

1. Insert the **lower clamp** of the Cover plate into the groove on the track and slide the Cover plate in the middle of the track.

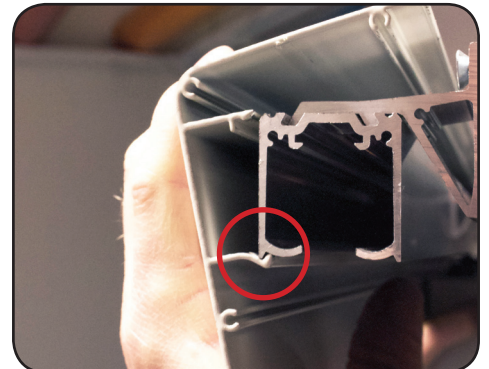

2. Use one hand to hold the Cover plate on the track and with another hand, press the upper clamp of the Cover plate to its place starting from the end of the track.

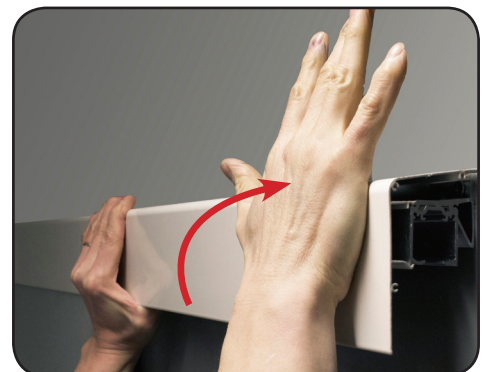

Proceed this way along the entire track, moving only one hand at a time.



At each point, make sure that the lower clamp is in place before attempting to press the upper clamp. If the Track is not straight, you will need to use more force to hold the upper clamp in the track.

3. Finish with End caps.

Remove the protective films on both sides of the End caps. Fix the end caps with the screws provided. You will need a Torx 10 screwdriver.



---

## 10. Detaching the Cover plate

1. Remove the End caps.

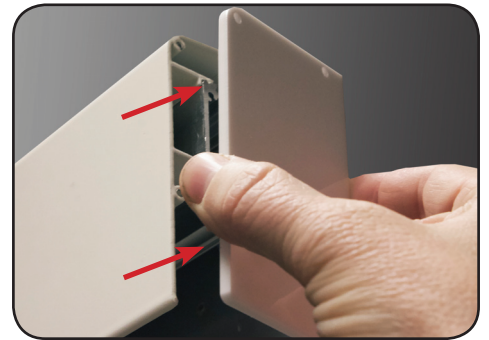

2. Twist the Cover plate slightly from the end at the bottom from the track.

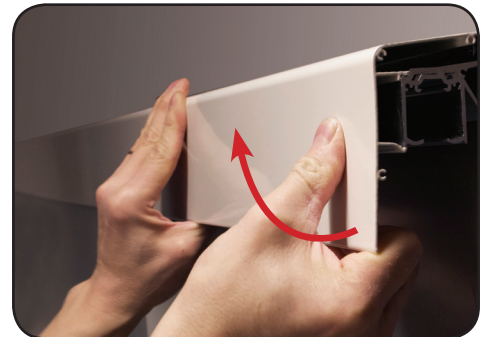

*NB! To get better support for twisting the cover plate, you can, for example, push about 10 mm thick "wooden block" into the track from below so that it goes into the T groove in the ceiling of the track. Hold the block against the wall as you remove the cover plate. Do not use any hard metal instead of a barrel to avoid damaging the track.*



Scale image

